



features

- Integrated flash controller
- User management
- Password protection
- Backup & Restore function
- Coordinate transformation
- flexible result conjunction



general data

resolution	1280 × 960 px
sensor type	1/3" CCD, monochrome
external illumination	as accessory
high-resolution mode	max. 12 inspections per second
high-speed mode (limited resolution)	max. 25 inspections per second
number of jobs (products)	≤ 255
features per job	32
defect image memory	8
signal processing	Baumer FEX® 4.0
illumination	direct connection (integrated flash controller)
lens	C-mount

electrical data

voltage supply range +Vs	18 ... 30 V DC
power consumption	typical 5 W ($I_{max} = 1,5 \text{ A}$ at 24 V)
digital inputs	5 inputs (8 ... 30 V) trigger job selection external teach-in encoders (CH-A, CH-B) 500 kHz
digital outputs	3 outputs (PNP) Pass / Fail Flash Sync Alarm Camera Ready Output Enable
initial setup	Ethernet (10BASE-T / 100BASE-TX)
process interface	TCP UDP (Ethernet) / RS485 (supports VeriSens® Gateways)
visualization	web interface

integrated flash controller

voltage	12 V DC or 24 V DC (permanent) 24 V DC or 48 V DC (pulsed)
current	$I_{max} = 800 \text{ mA}$ at 24 V DC (permanent) (±10 %, at least ± 100 mA, at 25 °C) $I_{max} = 4 \text{ A}$ at 48 V DC (pulsed) (+10/-20 %, at least ± 100 mA, at 25 °C)
flash time	max. 1 ms (Duty Cycle max. 1:10)

mechanical data

width	53 mm (without lens/tube)
height	99,5 mm (without lens/tube)
depth	49,8 mm (without lens/tube)
material	housing: aluminum cover glass: PMMA
weight	≤ 300 g (without lens/tube)

environmental conditions

operating temperature	+5 ... +50 °C
storage temperature	-20 ... +70 °C
case temperature	max. +50 °C
humidity	0 ... 90 % (non-condensing)
protection class	IP 67 (with tube)
vibration load	IEC 60068-2-6 IEC 60068-2-64
mechanical shock resistance	EN 60068-2-27

feature checks

part location	part location on contours part location on edges part location on circle part location on text line
---------------	--

feature checks

geometry	distance
	circle
	angle
	count edges
	point position
	edge characteristics
feature comparison	count contour points
	contour comparison
	brightness
	contrast
	area size
	count areas
	pattern comparison

electrical connection M12 / 12-pin (on device)



1: PWR (+18-30 V DC)	7: OUT3
2: Ground	8: IN3
3: IN1 (Trigger)	9: RS485+
4: OUT1	10: IN4
5: IN2	11: IN5
6: OUT2	12: RS485-

Ethernet connection M12 / 4-pin (on device)



1: TD+	3: TD-
2: RD+	4: RD-

electrical connection illumination M8 / 4-pin (on device)



1: +24 V or +48 V Flash	3: Ground
2: +12 V or +24 V Flash	4: Flash Sync

voltage outputs configurable by software

dimension drawing

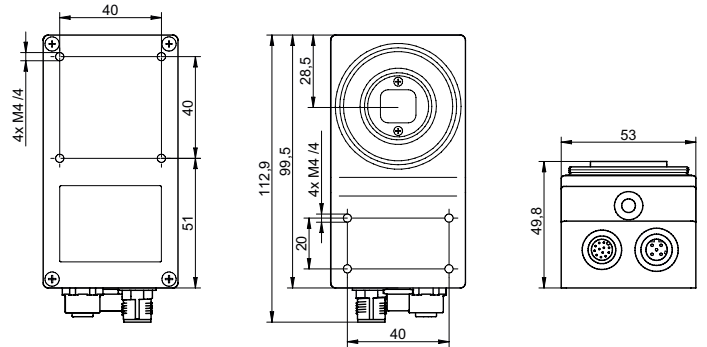

C-mount support

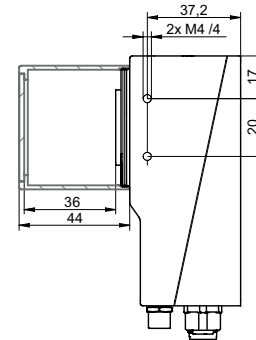

XC Tube, XC Tube Module

